

# MICROSTRUCTURE AND MECHANICAL PROPERTIES OF NICKEL- CHROME - BOR - SILICON LAYERS PRODUCED BY THE ATMOSPHERIC PLASMA SPRAY PROCESS

Mrdak R. *Mihailo*, IMTEL Institute of Microwave Techniques and Electronics, Belgrade

FIELD: Chemical Technology

ARTICLE TYPE: Original Scientific Paper

## Summary:

*This paper analyzes the influence of plasma spray parameters on the microstructure and mechanical properties of NiCrBSi coatings deposited by the atmospheric plasma spray (APS) process. The microstructure and mechanical properties of plasma spray coatings are determined by the interaction of plasma ions with powder particles when the rate and temperature of plasma particles are transferred to powder particles. The interaction effect directly depends on the time the powder particles spend in plasma, and that time is defined by the deposition distance for each type of powder, depending on the grain size, melting temperature and specific mass. In order to obtain homogeneous and dense coatings, three distances (70, 120 and 170 mm) from the substrate were used in the research. The coating of the best structural and mechanical characteristics was remelted and fused to the base in order to obtain a better structure. Self - fluxing NiCrBSi alloys are widely used because of the good resistance of boride, carbide and silicide solid phases to wear and corrosion. The morphology of powder particles was examined in the SEM (Scanning Electron Microscope), while the microstructure of the layers was assessed using a light microscope. The microstructural analysis of the deposited layers was performed in accordance with the Pratt-Whitney standard. The mechanical properties of the layers were assessed by applying the HV0.3 method for microhardness testing and tensile testing was applied to test bond strength.*

Key words: (APS) atmospheric plasma spray process, microstructure, interface, microhardness, bond strength, NiCrBSi layer.

## Introduction

Nickel-based materials with the addition of a certain percentage of alloying elements such as Cr, Si and B have almost the same resistance to wear and corrosion as cobalt-based materials. The

advantage of these alloys compared to the stellite is that they have a lower melting temperature, 1025 - 1150<sup>0</sup>C, as well as lower cost and thermal stability. The resistance to surface wear and tribological characteristics of the parts in most cases are determined by their operational functions. The atmospheric plasma spray (APS) process is a thermal process which enables the formation of coatings that provide mechanical parts with a longer life, greater reliability and a higher degree of safety in operation. This procedure is one of the procedures commonly used for the deposition of powders for repair of damaged and worn out machine parts, and for the protection of new parts from wear and corrosion. The coat deposition process consists of several phases: the powder melting, the collision of melted powder particles with the substrate material, the bonding of sprayed particles and the coating structure formation [1]. Plasma spray coatings deposited with inadequate parameters are characterized by weaker adhesion, low cohesion and high porosity. The options for improving these properties is the optimization of plasma spray parameters such as the plasma gun distance from the substrate and the deposition rate. In order to be wear and corrosion resistant, plasma spray coatings are required to have good adhesion, reduced porosity and a minor proportion of melted powder particles in the layers. In order to predict the behavior and service life of coatings, it is necessary to fully understand the relations between technology, process parameters, microstructure and the properties of coating layers. Due to a high temperature of melted powder particles and high temperature differences between particles and the substrate, residual stresses may occur with a negative impact on the coating characteristics. These features are primarily related to the adhesion and the cohesive strength of the lamellae in coating layers. Voltages can occur as a result of cooling and shrinkage of particles during the process as well as different thermal expansion coefficients between the coating and substrate surfaces [2-5]. Self-fluxing NiCrB-Si alloy powder was developed to produce coatings successfully used for the production and maintenance of equipment in all industries. Coatings are applied to increase the performance of surfaces of mechanical elements. NiCrBSi-type alloys are well known. Due to their specific properties, they have excellent resistance to abrasion and erosion wear up to 820<sup>0</sup>C, as well as corrosion resistance owing to hard phases in their structure [6,7]. These materials deposit well and have self-fluxing properties for the base material substrate. The ternary Ni-Cr-B alloy system has shown that alloys mostly have a three-phase structure consisting of a solid solution of chromium in nickel  $\gamma$  - Ni(Cr), nickel borides Ni<sub>3</sub>B and borides of chromium CrB and Cr<sub>5</sub>B<sub>3</sub>. Fig. 1. shows the ternary phase diagram of Ni-Cr-B alloy [8].

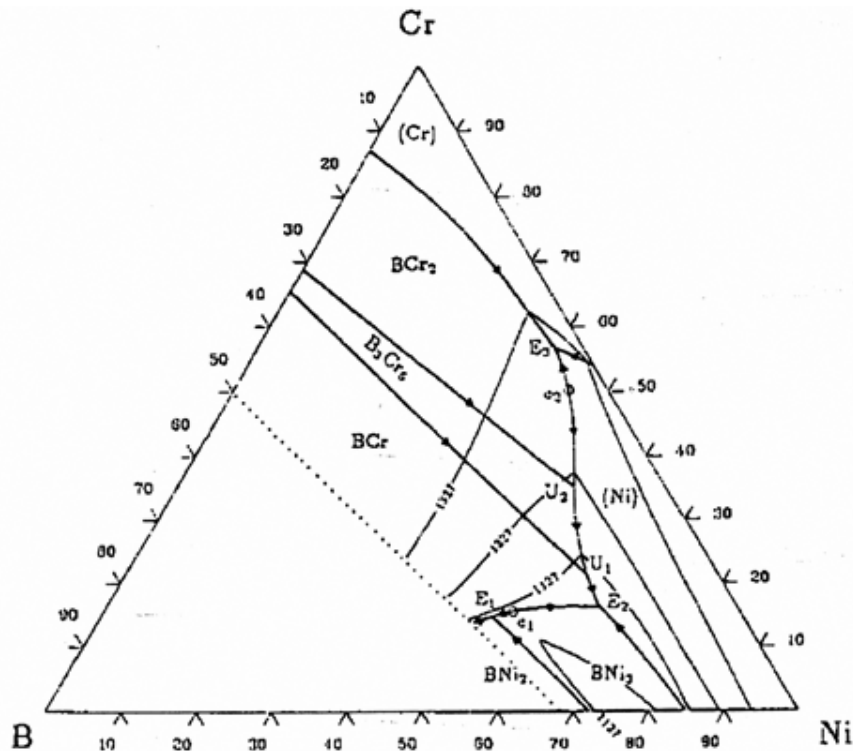

Figure 1 - Ternary phase diagram of Ni-Cr-B alloy [8]  
 Slika 1 - Ternarni sistem Ni-Cr-B [8]

Binary systems such as NiCr, NiB and NiSi provide information on the effects of individual alloying elements on the melting temperature of NiCrBSi alloys [9]. Binary systems show that Cr, Si and B reduce the melting temperature of Ni to 1040°C. The result is a relatively low melting temperature of NiCrB-Si alloys [10]. After remelting NiCrSi alloys, the published studies [11,12] have contributed to the recognition of the phases of NiCrBSi systems. The base of the NiCrBSi alloy contains a solid solution  $\gamma$  - Ni with a low content of Ni-Ni<sub>3</sub>B eutecticum. During remelting, there may be an increase in chromium carbide precipitates (Cr<sub>7</sub>C<sub>3</sub>) where the carbon content in the chemical composition of the coating exceeds 0.8 wt%. In addition, if the content of boron in the coatings is higher than 2 wt.%, the microstructure contains CrB precipitates [13]. Silicon is present almost entirely in the form of mixed crystals. The increase of the Si content for more than 3.2% results in the presence of chromic silicides Cr<sub>5</sub>Si<sub>3</sub>. A higher content of B and Si significantly lowers the plastic properties of the NiCr alloy. The most effective influence on the B and C hardness can be explained by their participation in the formation of borides and carbides. The Ni alloy deposition process is the overall proportion of B in the form of bo-

rides CrB and Ni<sub>3</sub>B[8]. Boron is added to the alloy as a deoxidation agent because of the sensitivity of individual alloy components to oxygen at high temperatures and because of the formation of boride solid phases. The coatings are thick with a hardness of 60 - 62HRc. This is recommended for difficult operating conditions when a base material with a high coefficient of thermal expansion ( $8 - 9 \times 10^{-6} \text{ K}^{-1}$ ) is used [6].

The improvement of the coating can be achieved with the application of the process of remelting the deposited layers, which, however, can lead to a decline in toughness. Remelting and fusing the NiCrBSi coating is very important because of the presence of numerous micro cracks and crackings that can affect a wider use. The content of cracking depends on stress as a consequence of the alloy remelting rate and substrate preheating. Speed remelting significantly affects the crystallization process layers directly related to the chemical composition of the alloy and its properties. For each type of the NiCrBSi alloy, it is necessary to examine the proportion of the resulting stresses depending on the melting process, which is directly related to the process of crystallization and cooling rate of layers [14]. For the process of coating remelting, the speed of preheating layers and the substrate on which the coating is deposited is very important as well as the temperature distribution in the depth of the entire sample. For high remelting and crystallization rates, a heterogeneous structure is characterized as well as a high sensitivity of layers to crack formation. Since the temperature in the melting zone is not uniform, the structure of the coating is not homogeneous in depth and width of the remelting and fusion. The primary crystals of chromium carbides and chromium borides, formed with sharp edges, are the main causes of stress concentrated at the grain boundaries that create micro-cracks at the boundaries of dendrites. The crack through the coating and at the interface is of dendrite character. The number of crackings can be controlled and reduced by the rate of energy incorporated in the process of melting and fusion. For a low remelting rate, when the substrate material has enough time to preheat, longitudinal cracks do not appear in the coating. The applied remelting method and rate affect the phase composition, grain size, texture, and the dissolution of carbides in nickel, i.e. the mechanical and tribological properties of layers with time [7,14]. In any case, the characteristics of functional coatings are affected by powder deposition parameters.

The main objective of this paper was to homogenise NiCrBSi coating layers and apply them to the aircraft parts exposed to combined wear and excessive corrosion. Three groups of samples were obtained at three distances (70, 120 and 170 mm) of the plasma gun from the substrate. The coating with the best microstructure was melted down and fused with the substrate. We analyzed and studied the microstructure and mechanical characteristics of the coating layers in order to select the highest quality coating and homologue the plasma spray parameters.

## Materials Testing and Samples

The powder GTV 80.15.1 (DIN EN 1274) of the self-fluxing NiCrBSi alloy was used for the coating [6]. The powder particles, of spherical morphology, are made by melting and the atomization of the liquid melt with an inert gas. The powder used in the experiment had a range of granulation from – 53 to + 20  $\mu\text{m}$ . The melting temperature of the powder was 1024  $^{\circ}\text{C}$ . Fig. 2 shows a (SEM) scanning electron micrograph of the morphology of the powder particles. The powder base consists of a solid solution of chromium in nickel  $\gamma$  - Ni(Cr) and the solid phases of CrB, Cr<sub>3</sub>Si, Ni<sub>3</sub>B, and NiSi. Table 1 shows the chemical composition of the NiCrBSi powder.

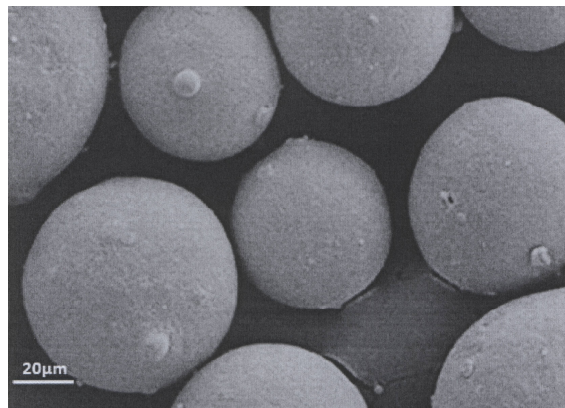

Figure 2 - (SEM) Scanning electron micrograph of the NiCrBSi powder particles  
Slika 2 - (SEM) Skenirana elektronska mikrofotografija čestica praha NiCrBSi

Table 1. Chemical composition of the NiCrBSi powder  
Tabela 1. Hemijski sastav praha NiCrBSi

Chemical composition of the NiCrBSi powder	(%)
Cr	14.0
Fe	4.5
Si	4.5
B	3.3
C	0.75
Ni - to balance	72.95

The bases with the deposited coating for microhardness testing were made of steel Č.4171 (X15Cr13 EN10027) in a thermally non-treated state with the dimensions 70x20x1.5mm [15]. The bases for bond strength testing were also made of steel Č.4171 (X15Cr13EN10027) in a thermally non-treated state with the dimensions  $\phi$  25x50 mm [15].

## Examination of microhardness, bond strength and microstructure

The mechanical properties of the layers were assessed by microhardness testing using the HV0.3 method and by testing bond strength using tensile testing. The microhardness was measured along the lamellar structure, in the middle and at the ends of the samples. The results of five readings were averaged.

The method applied for bond strength testing is the method of tensile testing. The testing was done at room temperature with a tensile rate of 1cm/60s. Three specimens were tested for each group of samples.

The SEM was applied for the examination of the morphology of powder particles. The microstructure of the layers in the deposited condition and after etching was tested by a light microscope. The etching of the electrolytic plating was done with 2% Cr acid and by the immersion in a saturated solution of  $\text{KMnO}_4$  with 8% NaOH.

## Powder deposition

The process of coating deposition on the metal base was done by atmospheric plasma spraying (APS). Coatings were deposited on steel bases, the surface of which was made rough white precious electro corundum grit from 0.7 mm to 1.5 mm. Coating deposition was performed with the Plasmatyne atmospheric plasma spraying (APS) system [16]. Fig. 3 shows the cross section of the SG - 100 plasma gun, consisting of a K 1083 -129 cathode (3), an A 2083 -129 anode (4) and a GI 2083 -130 gas injector (1).

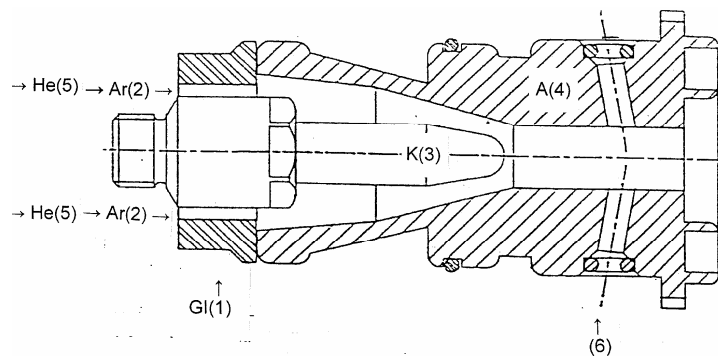

Figure 3 - Cross-section of the SG-100 plasma gun

(1) - gas injector type GI 2083 -130, (2) - gas argon Ar, (3) - cathode type K 1083 -129, (4) - anode type A 2083 -129, (5) - gas helium He, (6) - openings

Slika 3 - Poprečni presek plazma pištolja SG-100:

(1) - gas injektora tip GI 2083 -130, (2) - gas argon Ar, (3) - katoda tip K 1083 -129, (4) - anoda tip A 2083 -129, (5) - gas helijum He, (6) - otvori

The parameters for depositing NiCrBSi layers are shown in Table 2.

*Table 2 - Plasma spray parameters*

*Tabela 2 - Plazma sprej parametri.*

Deposition parameters	Values
Electric current (A)	700
Arc voltage (V)	39
Primary plasma gas Ar (l/min)	47
Secondary plasma gas He (l/min)	50
Wearing a powder gas Ar (l/min)	4
Flow of powder (g/min)	60
Distance of the substrate (mm)	70/120/170

Through the gas injector hole (1), primary arc gas argon Ar (2) was injected to flow between the cathode (3) and the anode (4). A plasma arc - an electric arc was formed by introducing direct current between the cathode and the anode. After the electric arc stabilization, secondary gas helium He (5) was injected through the gas injector hole followed by its momentary ionization. As the electric arc circuit was completely closed, the ionized secondary gas left the anode opening as a focused plasma jet. At the exit of the anode plasma has high rate and temperature. During the process, plasma ions and electrons recombine into atoms thus releasing a great amount of heat which melts the injected powder in the anode. The anode has two openings (6) for powder injection into the plasma jet. The powder deposition was done with a mixture of plasma gases Ar-He and the power supply of 40KW. Three groups of samples, A, B and C, were obtained with three distances of powder deposition (70.120 and 170 mm). The layers were deposited on the substrates of a total thickness of 0.030 to 0.035 mm with a plasma gun rate of 500mm/s. The coating with the best structural and mechanical characteristics was melted and fused to the base. The melting was done with an oxy - acetylene flame at 1050°C.

## Results and discussion

The results of the tests of microhardness and bond strength of Ni-CrBSi layers are shown in Table 3 and in the diagrams (Figs. 4 and 5).

*Table 3 - The values of microhardness and bond strength of NiCrBSi layers*

*Tabela 3 - Vrednosti mikrotvrdoće i čvrstoće spoja slojeva NiCrBSi*

Substrate	NiCrBSi	
	Microhardness HV <sub>0.3</sub>	Bond strength MPa
A	823	0.9
B	890	53
C	454	22

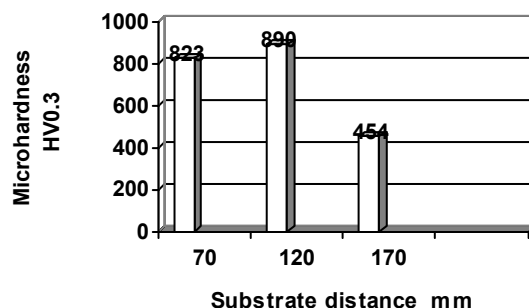

Figure 4 - Microhardness of NiCrBSi layers  
Slika 4 - Mikrotvrdoća NiCrBSi slojeva

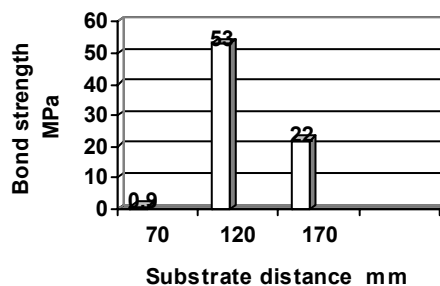

Figure 5 - Bond strength of NiCrBSi layers  
Slika 5 - Čvrstoća spoja NiCrBSi slojeva

The values of the microhardness of coating layers are directly related to the distance of powder deposition. The layers of the coating deposited with the largest distance of 170mm on the substrate (C) have the lowest value of microhardness - 454HV<sub>0.3</sub>. A greater distance from the substrate resulted in a greater reduction in rate and in subcooling of melted powder particles. This further resulted in less sagging and the deposition of particles on each other, accompanied by a large proportion of pores.

This was confirmed by the metallographic examination of the coating layers. The highest value of microhardness of 890 HV<sub>0.3</sub> was found in the layers with the lowest content of pores, deposited on the substrate (B) with a distance of 120 mm. A high values of microhardness 823HV<sub>0.3</sub> were also found in the layers deposited on the substrate (A) with the shortest distance of 70 mm. The microhardness values of these coatings were accompanied by defects at the interface in the form of crackings due to a high stress state caused by a small distance of the plasma powder deposition.

The bond strength of the coatings is directly related to the distance of powder deposition and the content of pores in the layers. The lowest value of the bond strength, 0.9 Mpa, was found the layers deposited with a substrate distance of 70 mm. The stresses at the interface occurred at a short



distance due to significant temperature differences between the deposited melted powder particles and the substrate. Rapid cooling and contraction of the particles as well as different thermal expansion coefficients between the coating and the substrate influenced the formation of cracking at the interface. This type of error in the coating was identified during the examination of the microstructure of the layers. Cracks significantly reduce adhesion. The destruction of the coating on the sample (A) was initiated by the existing cracks at the interface at the point with the highest state of stress. The cracks propagated through the surface of the coating with good bonding with the substrate. The highest value of the bond strength of 53MPa was found in the layers with the lowest content of pores, deposited on the substrate (B) with a distance of 120 mm. The mechanism of destruction on the sample (B) was of the adhesive type at the interface between the substrate and the bonded coating. The layers of the coating deposited at the highest substrate distance of 170 mm had a bond strength value of 22 Mpa, which was influenced by a high content of pores in the layers. Due to a high content of coarse pores, the mechanism of destruction occurred through the pores of the coating layer near the interface.

Figs. 6.7 and 8 show the microstructures of the deposited layers on the substrates A, B and C with the distances of 70, 120 and 170 mm. Fig. 9 shows the microstructure of the coatings deposited on the substrate with a magnification of 800x in order to analyze the microstructure of the layers with the best structural and mechanical properties. The qualitative analysis of the deposited NiCrBSi layers showed that  $Al_2O_3$  particles from roughening were not present at the substrate/coating interface.

Fig. 6 shows an existing crack propagating along the interface between the substrate and the coating. The coating/substrate bond is intermittent without the separation of the coating layers from the substrate.

The coating layers are dense without the presence of unmelted particles, pores and micro cracks in the deposited layers.

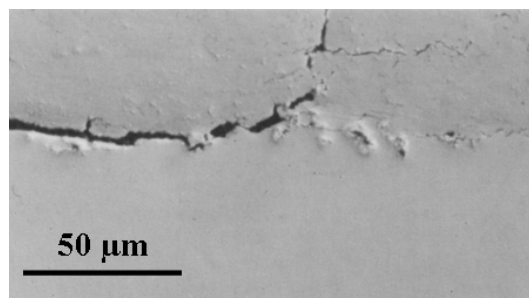

Figure 6 - Microstructure of the NiCrBSi coating deposited on the sample A with a substrate distance of 70 mm

Slika 6 - Mikrostruktura NiCrBSi prevlake deponovane na uzorku A sa odstojanjem supstrata 70 mm

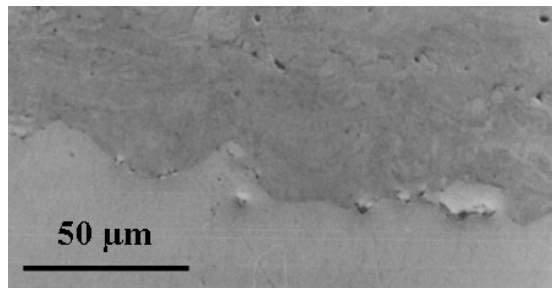

Figure 7 - Microstructure of the NiCrBSi coating deposited on the sample B with a substrate distance of 120 mm

Slika 7 - Mikrostruktura NiCrBSi prevlake deponovane na uzorku B sa odstojanjem supstrata 120 mm

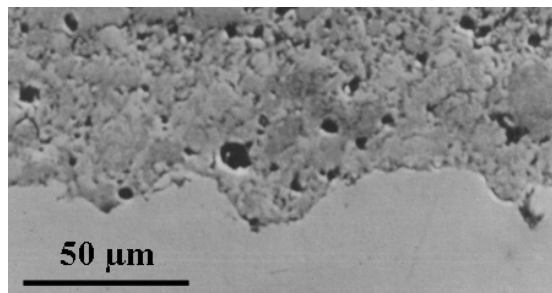

Figure 8 - Microstructure of the NiCrBSi coating deposited on the sample C with a substrate distance of 170 mm

Slika 8 - Mikrostruktura NiCrBSi prevlake deponovane na uzorku C sa odstojanjem supstrata 170 mm

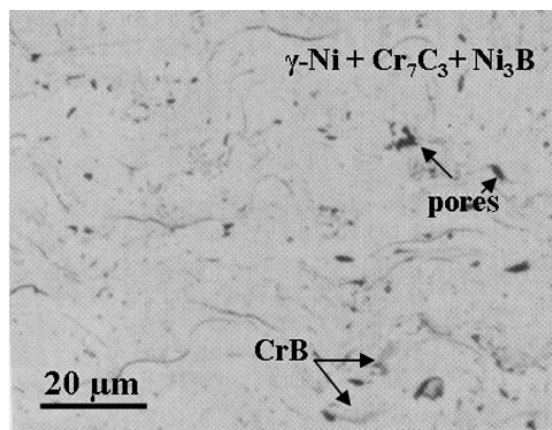

Figure 9 - Microstructure of the NiCrBSi coating deposited on the sample B with a substrate distance of 120 mm

Slika 9 - Mikrostruktura NiCrBSi prevlake deponovane na uzorku B sa odstojanjem supstrata 120 mm

Fig. 7 shows the NiCrBSi layers deposited on the substrate B with the best structural and mechanical characteristics. The coating structure is lamellar with a good bond to the substrate. The layers are deposited on the substrate continuously without interruption and without the presence of micro and macro cracks on the interface. The layers are very dense and homogeneous with a very low content of pores, lower than 1%. The layers do not contain unmelted particles. Micro cracks cannot be observed through the deposited layers.

In the microstructure of the NiCrBSi layers deposited with the longest distance of the plasma gun, shown in Fig. 8, a large content of non lamellar particles and pores can be seen. A long distance of the plasma gun from the substrate resulted in the subcooling of the melted powder particles and they plastically deformed on the impact with the substrate, forming coarse black pores.

The morphology of the deposited particles is of an irregular shape. Non melted particles without the presence of micro and macro cracks are identified in the structure as well. Discontinuities in the coating, caused by the presence of porosity and unmelted particles, facilitate wear and lower corrosion resistance at interlamellar boundaries.

The structure of the coating on the substrate B is lamellar (Fig. 9). The basis of the coating consists of a solid solution of chromium in nickel  $\gamma$  - Ni which includes fine precipitates  $\text{Cr}_7\text{C}_3$  and  $\text{Ni}_3\text{B}$  [7,17]. Through NiCrBSi layers, dark lamellae of the phases of chromium borides CrB are clearly seen. Fine pores with fine NiCrBSi precipitates can be also observed. These phases are mainly present in the coating layer after the plasma spray deposition [13]. In the coating structure, following the binary systems of CrC and BC, the  $\text{Cr}_7\text{C}_3$  phase is present out of all carbide phases [9]. In order for the  $\text{Cr}_3\text{C}_2$  phase to be formed in the structure, the carbon content in the coating must be  $\text{C} > 0.8$  wt%, and for the  $\text{B}_4\text{C}$  type of carbide, the carbon content must be in the range from 10 to 20.9 wt% [9].

Fig. 10 shows the microstructure of the remelted coating deposited on the substrate B. The structure of the coating is homogeneous, without any present micro and macro cracks. This indicates that the coating layers were evenly heated and remelted. The microstructure consists of the Ni solid solution and the phases of  $\text{Ni}_3\text{B}$ , CrB,  $\text{Cr}_7\text{C}_3$  and  $\text{Ni}_5\text{Si}_2$ . The structure of the primary solid solution  $\gamma$  - Ni is dendritic with hard eutectics of  $\gamma$  - Ni -  $\text{Ni}_3\text{B}$  and  $\gamma$  - Ni -  $\text{Ni}_3\text{B}$  - CrB. Between the Ni dendrites there are primary crystals and the dendrites of  $\text{Cr}_7\text{C}_3$  carbide which are lighter in color and form a part of the eutectic  $\text{Cr}_7\text{C}_3$  -  $\text{Ni}_3\text{B}$ . The primary  $\text{Cr}_7\text{C}_3$  and  $\text{Ni}_5\text{Si}_2$  particles are found in the interdendritic areas. The etching of the coating causes Ni to dissolve from the solid solution and the eutectics, while borides, carbides and silicides are raised in the relief. Since the incident light falls on the surface obliquely and casts a shadow over the raised boride, carbide and silicide phases, nickel dendrites are black.

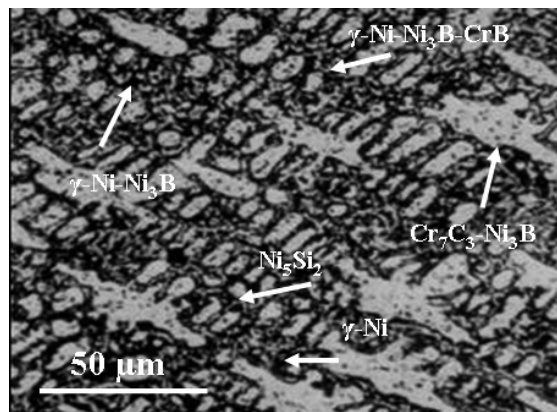

Figure 10 - Microstructure of the melted NiCrBSi coating deposited on the sample B with a substrate distance of 120 mm

Slika 10 - Mikrostruktura NiCrBSi prevlake deponovane na uzorku B sa odstojanjem supstrata 120 mm

During the remelting of the coating layers, the basic phase rich in  $\gamma$  - Ni nickel forms a binary eutectic  $\gamma$  - (Ni) -  $\text{Ni}_3\text{B}$  with the  $\text{Ni}_3\text{B}$  boride primary phase at  $1042^\circ\text{C}$ . The solidification of the coating layer ends at  $997^\circ\text{C}$  with a triple eutectic reaction forming the triple lamellar eutectic  $\gamma$  - Ni + CrB +  $\text{Ni}_3\text{B}$  [18, 19].

## Conclusion

In this paper, the atmospheric plasma spray (APS) process was applied for the deposition on three groups of samples A, B and C, from three distances (70, 120 and 170 mm) by a plasma gun. The structure and the mechanical properties of the coatings deposited were studied and analyzed, leading to the following conclusions.

The microstructure and the mechanical properties of the bond hardness and strength depend directly on the distance of the plasma gun from the substrate.

Shorter and longer distances of the powder deposition resulted in the coating layers with lower coating adhesion. A shorter distance resulted in the formation of cracking at the interface, and a longer distance gave rise to the formation of coarse pores in the layers.

The layers with the best structural and mechanical properties were obtained with a distance of 120mm from the substrate. The layers are dense and homogeneous with high hardness and adhesion.

The structure of the deposited coating layers is lamellar and is mainly composed of a solid solution of chromium in nickel  $\gamma$  - Ni(Cr) and hard phase borides CrB,  $\text{Ni}_3\text{B}$  and carbides  $\text{Cr}_7\text{C}_3$ .

The remelted coating does not contain micro crackings. The structure of the primary solid solution  $\gamma$  - Ni is dendritic with the hard eutectics  $\gamma$  - Ni - Ni<sub>3</sub>B and  $\gamma$  - Ni - Ni<sub>3</sub>B - CrB. Between the Ni dendrites there are primary crystals and dendrites of Cr<sub>7</sub>C<sub>3</sub> carbide, lighter in color as a part of the eutectic Cr<sub>7</sub>C<sub>3</sub> - Ni<sub>3</sub>B. Primary Cr<sub>7</sub>C<sub>3</sub> particles and Ni<sub>5</sub>Si<sub>2</sub> are in the inter dendritic regions.

The results have shown that the distance of the substrate influences the structure and the mechanical properties of the coating layers. The tests have confirmed that the best coating layers are those deposited with a substrate distance of 120 mm. Remelting of layers further improves the structure of the coating.

### Literature

- [1] Dobrzański, L.A., *Podstawy nauki o materiałach i metaloznawstwo (Fundamentals of Material Science and Metallography)*, WNT, Warsaw, 2002.
- [2] Totemeier, T.C., Wright, J.K., *Surface and Coatings Technology*, 200 (2006)12 -13, 3955-3962.
- [3] Lordanova, I., Forcey, K.S., *Surface and Coatings Technology*, 91 (1997), 174 -182.
- [4] Pina, J., Dias, A., Lebrun, J.L., *Materials Science and Engineering A -Structural Materials Properties Microstructure and Processing*, 347 (2003) 1-2, 21-31.
- [5] Ishida, T., Setoguchi, K., Hiraki, K., *JSME International Journal Series A-Solid Mechanics and Material Engineering*, 42 (1999) 1, 119-125.
- [6] GTV Spray powder catalogue, GTV Spray powders comply with DIN EN 1274, Materials number 80.15.1 based on nickel (Self fluxing alloys)II.
- [7] Mrdak, M., *Karakterizacija WCCo/NiCrBSi prevlake otporne na habanje, Vojnotehnički glasnik/Military Technical Courier*, Vol. 58, No. 2, pp.43 – 52, Ministarstvo odbrane Republike Srbije, Beograd, 2010.
- [8] Villars, P., Prince, A., Okamoto, H., *Handbook of ternary alloy phase diagrams .Metals Park.*, OH : ASM International ,1995.
- [9] ASM Handbook, Volume 3, Alloy Phase Diagrams, ASM International, Metals Park, 1992.
- [10] "Produkt - und Anwendungs-Informationen," Castolin Eutectic GmbH, Wien, Austria, 2005 (in German).
- [11] Gonzales, R., Garcia, M. A., Penuelas Cadenas, I., Ma del Rocio Fernandez, M., Hernandez Battez, A., and Felgueroso, D., *Microstructural Study of NiCrBSi Coatings Obtained by Different Processes*, *Wear*, 2007, 263, p 619-624.
- [12] Shrestha, S., Neville, A., and Hodgkiess, T., *The Effect of Post- Treatment of a High-Velocity Oxy-Fuel Ni-Cr-Mo-Si-B Coating Part I: Microstructure/Corrosion Behaviour Relationships*, *J. Therm. Spray Technol.*, 2001, 10(3), pp. 470-479.
- [13] Kim, H. J., Hwang, S. Y., Lee, C. H., and Juvanon, P., *Assessment of Wear Performance of Flame Sprayed and Fused Ni-Based Coatings*, *Surf. Coat. Technol.*, 2003, 172, p 262-269.

[14] Spiridonov, N. V., Kardapolova, M. A., *Control of Composite Coatings Using Self – Fluxing Alloys and Laser Surface Treatment*, Plasma - Technik - Symposium, Lucerne May 18<sup>th</sup> to 20<sup>th</sup>, Vol. 2, pp. 165-170, 1988.

[15] Turbojet Engine – Standard Practices Manual (PN582005), Pratt & Whitney, East Hartford, USA, 2002.

[16] Mrdak, M., *Uticaj brzine depozicije praha na mehaničke karakteristike i strukturu APS – NiCr/Al prevlake*, Vojnotehnički glasnik/Military Technical Courier, Vol. 58, No. 4, pp. 5-16, Ministarstvo odbrane Republike Srbije, Beograd, 2010.

[17] Serres, N., Hlawka, F., Costil, S., Langlade, C., and Machi, F., Microstructures of Metallic NiCrBSi Coatings Manufactured via Hybrid Plasma Spray and In Situ Laser Remelting Process, Journal of Thermal Spray Technology, Published online, 12 November 2010.

[18] Ohsassa, K., Shinimura, T., Narita, T., (1999) J Phase Equilibria 20:199.

[19] Shrivastava, P. K., Tiwari, A. N., and Gopinathan, V., 1989, "Role of Boron in Fe- and Ni-based Rapidly Solidified Microcrystalline Alloys", Key Engineering Materials, Vols. 38-39, pp.143 -162.

#### MIKROSTRUKTURA I MEHANIČKE OSOBINE NIKAL - HROM - BOR - SILICIJUM SLOJEVA PROIZVEDENIH PLAZMA SPREJ POSTUPKOM PRI ATMOSFERSKOM PRITISKU

OBLAST: hemijske tehnologije

VRSTA ČLANKA: originalni naučni rad

##### Sažetak:

*U ovome radu analiziran je uticaj plazma sprej parametara na mikrostrukturu i mehaničke karakteristike NiCrBSi prevlaka deponovanih (APS) postupkom na atmosferskom pritisku. Mikrostruktura i mehanička svojstva plazma sprej prevlaka određena su interakcijom jona plazme sa česticama praha pri čemu nastaje prenos brzine i temperature čestica plazme na čestice praha. Efekat interakcije je u direktnoj zavisnosti od vremena boravka čestica praha u plazmi koji je definisan odstojanjem depozicije za svaki tip praha zavisno od granulacije, temperature topljenja i specifične težine. S ciljem dobijanja homogenih i gušćih prevlaka, u istraživanju su korišćenja tri odstojanja od supstrata: 70, 120 i 170 mm. Prevlaka najboljih strukturnih i mehaničkih karakteristika pretopljena je i fuzirana sa osnovom s ciljem dobijanja bolje strukture. Samovezujuće legure NiCrBSi imaju široku primenu zbog dobre otpornosti tvrdih faza borida, karbida i silicida na habanje i koroziju. Morfologija čestica praha je ispitana na SEM-u (skening elektronskom mikroskopu), dok je mikrostruktura slojeva procenjena na svetlosnom mikroskopu. Mikrostruktorna analiza deponovanih slojeva urađena je u skladu sa standardom Pratt-Whitney. Procena mehaničkih karakteristika slojeva urađena je ispitivanjem mikrotvrdoće metodom HV<sub>0,3</sub> i čvrstoće spoja ispitivanjem na zatezanje.*

## Uvod

Plazma sprej postupak (APS) jedan je od termičkih postupaka koji omogućava izradu prevlaka, koje mašinskim delovima povećavaju radni vek, pouzdanost i stepen sigurnosti u radu. Ovaj postupak jedan je od postupaka koji se najčešće koristi za depoziciju prahova za reparaciju oštećenih i pohabanih mašinskih delova, kao i za zaštitu novih delova od habanja i korozije. Proces izrade prevlake sastoji se od više faza: topljenja praha, sudara istopljenih čestica praha sa osnovnim materijalom supstrata, vezivanja nanetih čestica i stvaranja strukture prevlake. Zahteva se da plazma sprej prevlake otporne na habanje i koroziju imaju dobru adheziju, smanjenu poroznost i neznatan udeo nestopljenih čestica praha u slojevima. Da bi se predvidelo ponašanje i radni vek prevlaka, neophodno je da se u potpunosti razume odnos tehnologije, parametara procesa, mikrostrukture i svojstava slojeva prevlaka. Prah samovezujuće legure NiCrBSi razvijen je za izradu prevlaka koje se uspešno koriste za proizvodnju i održavanje opreme u svim industrijskim granama. Primeruju se za povećanje performansi površina mehaničkih elemenata. Legure tipa NiCrBSi dobro su poznate. Zbog specifičnih svojstava imaju odličnu otpornost do 820°C na abrazivno i erozivno habanje, kao i otpornost na koroziju zbog tvrdih faza prisutnih u strukturi. Ovi materijali dobro se deponuju i imaju samovezujuća svojstva za osnovni materijal supstrata. Trojni sistem Ni-Cr-B pokazuje da legure imaju uglavnom trofaznu strukturu koja se sastoji od čvrstog rastvora hroma u niklu, borida nikla Ni<sub>3</sub>B i borida hroma CrB i Cr<sub>5</sub>B<sub>5</sub>. Silicijum je prisutan skoro potpuno u obliku mešovitog kristala. Sa povećanjem sadržaja Si više od 3,2% prisutni su hromni silicidi Cr<sub>5</sub>Si<sub>3</sub>. Veći sadržaji B i Si značajno snižavaju plastična svojstva legure NiCr. Najefikasniji uticaj na tvrdoću imaju B i C, što se objašnjava njihovim učešćem u formiranju borida i karbida. U leguri Ni se u toku procesa depozicije celokupan udeo B nalazi u obliku borida CrB i Ni<sub>3</sub>B. Bor se dodaje leguri kao dezoksidans zbog osetljivosti pojedinih komponenti legure na kiseonik na visokim temperaturama i zbog stvaranja tvrdih faza borida. Prevlake su guste sa tvrdoćom od 60 do 62HRc. Preporučuje se za najteže uslove kada se koristi osnovni materijal sa prilično visokim koeficijentom topljnog širenja ( $8-9 \times 10^{-6} K^{-1}$ ).

Glavni cilj rada jeste da se homologuju slojevi NiCrBSi prevlake i primene na vazduhoplovnim delovima izloženim kombinaciji prekomernog habanja i korozije. Urađene su tri grupe uzoraka sa tri odstojanja plazma pištolja 70, 120 i 170 mm od supstrata. Prevlaka sa najboljom mikrostrukturom pretopljena je i fuzirana sa osnovom. Analizirane su i proučavane mikrostrukture i mehaničke karakteristika slojeva prevlaka da bi se na osnovu rezultata odabrala prevlaka najboljeg kvaliteta i homologovali plazma sprej parametri.

### Materijali za ispitivanje i uzorci

Za izradu prevlaka korišćen je prah GTV 80.15.1 (DIN EN 1274) samovezujuće legure NiCrBSi. Čestice praha izrađene su tehnikom topljenja i atomizacijom tečnog rastopa inernim gasom, koje pokazuju sfernu morfologiju. Prah koji je korišćen u eksperimentu imao je raspon granulacije od  $-53 + 20 \mu m$ . Temperatura topljenja praha je 1024°C.

Osnova praha sastoji se od čvrstog rastvora hroma u niklu  $\gamma$ -Ni(Cr) i tvrdih faza: CrB, Cr<sub>3</sub>Si, Ni<sub>3</sub>B, NiSi.

Ispitivanje mikrotvrdoće, čvrstoće spoja i mikrostrukture

*Procena mehaničkih svojstava slojeva urađena je ispitivanjem mikrotvrdoće metodom  $HV_{0,3}$  i čvrstoće spoja ispitivanjem na zatezanje. Merenje mikrotvrdoće izvršeno je u pravcu duž lamela, u sredini i na krajevima uzorka. Urađeno je pet očitavanja vrednosti i izabrana je srednja vrednost.*

*Metoda ispitivanja čvrstoće spoja je metoda ispitivanja na zatezanje. Ispitivanje je urađeno na sobnoj temperaturi sa brzinom zatezanja 1 cm/60 s. Za svaku grupu uzorka ispitane su po tri epruvete.*

*Ispitivanje morfologije čestica praha urađeno je SEM metodom. Mikrostruktura slojeva u deponovanom stanju i posle nagrizanja ispitana je tehnikom svetlosne mikroskopije. Nagrizanje prevlake rađeno je elektrolitički sa 2% Cr kiseline i potapanjem u zasićenom rastvoru  $KMnO_4$  sa 8% NaOH.*

*Prevlaka najboljih strukturnih i mehaničkih karakteristika pretočljena je i fuzirana sa osnovom. Pretapanje je rađeno oksiacetilenskim plamenom na 1050°C.*

Depozicija praha

*Proces nanošenja slojeva na metalne osnove urađen je plazma sprej postupkom na atmosferskom pritisku (APS). Prevlake su nanete na čelične osnove koje su ohrapavljene belim plemenitim elektrokorundom granulacije od 0,7 do 1,5 mm. Za izradu prevlaka korišćen je atmosferski plazma sprej sistem (APS) firme Plasmadyne.*

*Deponovanje praha urađeno je sa mešavinom plazma gasova Ar-He i sa snagom napajanja od 40 kW. Urađene su tri grupe uzorka A, B i C sa tri odstojanja depozicije praha 70, 120 i 170 mm. Slojevi su deponovani na supstratima ukupne debljine od 0,030 do 0,035 mm sa plazma pištoljem brzine 500 mm/s.*

Rezultati i diskusija

*Slojevi prevlake deponovani sa najvećim odstojanjem od 170 mm na supstratu (C) imaju najnižu vrednost mikrotvrdoće od 454HV<sub>0.3</sub>. Veliko odstojanje supstrata uticalo je na delimično pothlađenje i smanjenje brzine istopljenih čestica praha. To je uzrokovalo slabije razlivanje i deponovanje čestica jednih na druge praćeno velikim udelom međupora. Najveću vrednost mikrotvrdoće od 890 HV<sub>0.3</sub> imali su slojevi sa najmanjim udelom pora koji su deponovani na supstratu (B) sa odstojanjem od 120 mm. Visoke vrednosti mikrotvrdoće od 823HV<sub>0.3</sub> imali su i slojevi deponovani na supstratu (A) sa najmanjim odstojanjem od 70 mm. Vrednosti mikrotvrdoće ovih slojeva praćene su defektima na interfejsu u obliku prskotina zbog visokog naponskog stanja uzrokovanog malim odstojanjem plazma depozicije praha. Najveću vrednost čvrstoće spoja 53MPa pokazali su slojevi koji imaju najmanji udeo pora i koji su deponovani na supstratu (B) sa odstojanjem od 120 mm. Mehanizam razaranja na uzorku (B) bio je athezioni na interfejsu između supstrata i vezne prevlake. Slojevi prevlake deponovani sa najvećim odstojanjem supstrata od 170 mm imali su vrednost čvrstoće spoja 22 MPa koja je pod uticajem velikog udela pora u*



slojevima. Zbog velikog udela grubih pora mehanizam razaranja je išao kroz pore i slojeve prevlake u blizini interfejsa. Najnižu vrednost čvrstoće spoja 0,9 MPa pokazali su slojevi deponovani sa odstojanjem supstrata od 70 mm. Na malom odstojanju supstrata uneti su naponi na interfejsu usled visoke temperaturne razlike između istopljenih čestica praha i supstrata. Struktura prevlake na supstratu B je sa najboljim strukturnim i mehaničkim karakteristikama. Slojevi su deponovani na supstrat kontinualno bez prekida i bez prisustva mikro i makroprskotina na interfejsu. Slojevi su dosta gusti i homogeni sa izuzetno malim udelom pora ispod 1%. U slojevima nisu prisutne nestopljene čestice. Kroz deponovane slojeve se ne uočavaju mikroprskotine.

Osnova prevlake sastoji se od čvrstog rastvora hroma u niklu  $\gamma$  - NiCr sive boje u kojoj se nalaze fini precipitacijski faza borida i karbida. Kroz NiCrBSi slojeve jasno se uočavaju crne lamele faza hrom borida tipa CrB i hrom karbida  $Cr_7C_3$  i svetle faze nikal borida tipa Ni<sub>3</sub>B. To su faze koje su uglavnom prisutne u slojevima prevlake posle plazma sprej depozicije. U osnovi prevlake uočavaju se sitne pore u kojima se nalaze fini precipitacijski NiCrBSi čestice nastalih sudarom sa podlogom na koju se deponuju i primarnim očvršćavanjem. Faze borida i karbida ravnomerno su raspoređene kroz deponovane slojeve. Struktura pretopljene prevlake je homogena, bez prisutnih mikro i makroprskotina. To ukazuje da su slojevi prevlake ravnomerno progrejani i pretopljeni. Mikrostruktura se sastoji od čvrstog rastvora Ni i faza Ni<sub>3</sub>B, CrB, Cr<sub>7</sub>C<sub>3</sub>, Ni<sub>5</sub>Si<sub>2</sub>. Struktura primarnog čvrstog rastvora  $\gamma$  - Ni je dendritna sa tvrdim eutektikumima  $\gamma$  - Ni - Ni<sub>3</sub>B i  $\gamma$  - Ni - Ni<sub>3</sub>B - CrB. Između dendrita Ni nalaze se primarni kristali i dendriti karbida  $Cr_7C_3$  svetlije boje kao deo eutektikuma  $Cr_7C_3$  - Ni<sub>3</sub>B. Primarne čestice  $Cr_7C_3$  i Ni<sub>5</sub>Si<sub>2</sub> nalaze se u interdendritnim regionima. Nagrizanjem prevlake Ni se rastvara iz čvrstog rastvora i eutektikuma, dok boridi, karbidi i silicidi stoje izdignuti u reljefu. Pošto upadna svetlost koso pada na površinu uzorka i baca senku iznad izdignutih faza borida, karbida i silicida, dendriti nikla su crne boje.

#### Zaključak

Mikrostruktura i mehanička svojstva tvrdoće i čvrstoće spoja u direktnoj su zavisnosti od odstojanja supstrata od plazma pištolja.

Sa manjim i većim odstojanjem depozicije praha dobijeni su slojevi prevlaka sa manjom čvrstoćom spoja. Manje odstojanje uticalo je na formiranje prskotina na interfejsu, a veće odstojanje uticalo je na formiranje grubih pora u slojevima.

Slojevi sa najboljim strukturnim i mehaničkim karakteristikama dobijeni su sa odstojanja supstrata od 120 mm. Slojevi su gusti i homogeni sa visokom tvrdoćom i čvrstoćom spoja.

Struktura slojeva je lamelarna i uglavnom sastavljena od čvrstog rastvora hroma u niklu  $\gamma$  - Ni(Cr) i tvrdih faza borida CrB, Ni<sub>3</sub>B i karbida  $Cr_7C_3$ .

Struktura pretopljene prevlake je dendritna bez prisutnih mikroprskotina. Dendriti čvrstog rastvora Ni(Cr) su crne boje između kojih se nalaze pri-

*marni kristali  $Cr_7C_3$  svetle boje, dendriti CrB tamne boje, eutektikumi CrB -  $Ni_3B$  i  $Cr_7C_3 - Ni_3B$  i silicid  $Ni_5Si_2$ . Prevlaka je homogena i gusta.*

*Dobijeni rezultati pokazali su da odstojanje supstrata bitno utiče na strukturu i mehaničke karakteristike slojeva prevlaka. Ispitivanja prevlaka potvrdila su da su najbolji slojevi deponovani sa odstojanjem supstrata od 120 mm.*

*Ključne reči: (APS) Atmosferski plazma sprej postupak, mikrostruktura, interfejs, mikrotvrdoća, čvrstoća spoja, NiCrBSi sloj.*

Datum prijema članka: 13. 10. 2011.

Datum dostavljanja ispravki rukopisa: 26. 10. 2011.

Datum konačnog prihvatanja članka za objavljivanje: 28. 10. 2011.